

ETA 2000-1

TECHNICAL
COMMUNICATION

COMUNICACIÓN
TÉCNICA

COMUNICAZIONE
TECNICA

8³/₄'''

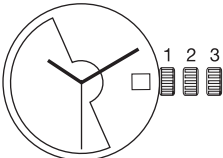
<p>8³/₄''' Ø 19,40 mm</p>	
<p>Height on movement Altura máquina Altezza movimento</p>	<p>3,60 mm</p>
<p>Running time / Reserva de marcha / Riserva di marcia Number of jewels / Número de piedras / Numero di pietre Frequency / Frecuencia / Frequenza Angle of lift of balance / Ángulo de alzamiento / Angolo de alzamento</p>	<p>40 h 20 28'800 A/h 50°</p>

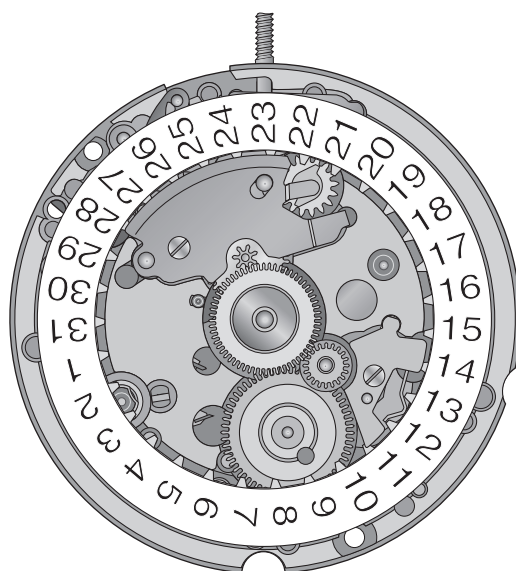
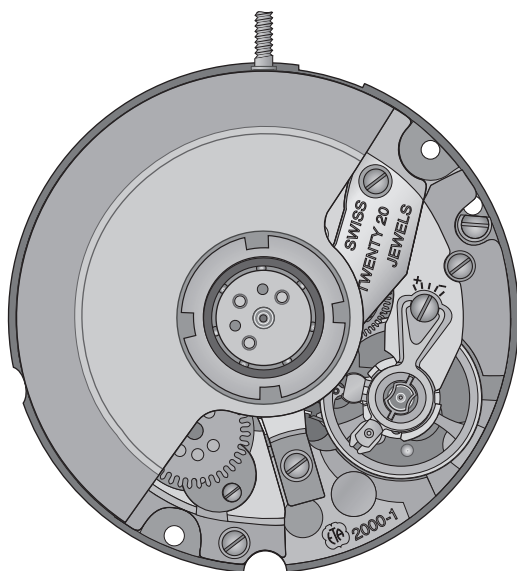











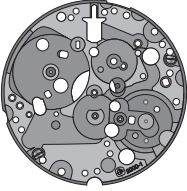
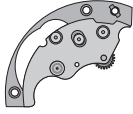























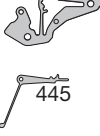







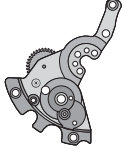

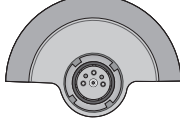



Interchangeability - Intercambiabilidad - Intercambiabilità

No No No	No No CS No	LIST OF MATERIALS	LISTA DE FORNITURAS	ELENCO DELLE FORNITURE	Cal. - Cal. - Cal	
					2000	2000-1
100	10.020.07	Main plate, jewelled	Platina empedrada	Piastra, con pietre	2000	2000-1
105/1	10.041.07	Barrel bridge, jewelled	Puente de cubo, empedrado	Ponte del bariletto, con pietre	2000	2000-1
110	10.048.07	Train wheel bridge, jewelled	Puente de rodaje, empedrado	Ponte del ruotismo, con pietre	2000	2000
121/4	10.058.24	Balance bridge for regulator with pointer, for shock-absorber, stud support ETACHRON, corrector	Puente de volante, para raqueta con flecha, amortiguador, porta-pitón ETACHRON y corrector	Ponte del bilanciere, per racchetta, con freccia, ammortizzatore, porta-pitone ETACHRON e correttore	2000	2000
125	10.057.07	Pallet bridge, jewelled	Puente de áncora, empedrado	Ponte dell'ancora, con pietre	2000	2000
144	10.300.00	Dial fastener	Sujetador del cuadrante	Ferma-quadrante	2000	2000
161	80.400.00	Centre tube	Tubito de centro	Tubo di centro	2000	2000
180/1	20.010.00	Movement barrel complete	Cubo completo de máquina	Bariletto completo del movimento	2000	2000-1
185	20.040.00	Barrel drum	Tambor de cubo	Tamburo del bariletto	2000	2000-1
190	20.050.00	Barrel cover	Tapa de cubo	Coperchio del bariletto	2000	2000
195	20.060.00	Barrel arbor	Árbol de cubo	Albero del bariletto	2000	2000
203	30.012.00	Intermediate wheel	Rueda intermedia	Ruota intermedia	2000	2000-1
210	30.025.00	Third wheel	Rueda primera	Ruota mediana	2000	2000
227	30.027.00	Second wheel	Rueda de segundos	Ruota dei secondi	2000	2000
227/3	30.027.28	Seond wheel, without sweep second	Rueda de segundos, sin segundero central	Ruota dei secondi, senza secondi al centro	2000	2000
242/1	31.083.06	Cannon pinion with driving wheel, without sweep second	Cañón de minutos con arrastrador, sin segundero central	Pignone calzante con conduttore, senza secondi al centro	2000	2000
242	31.083.00	Cannon pinion with driving wheel	Cañón de minutos con arrastrador	Pignone calzante con conduttore	2000	2000
255/1	31.046.06	Hour wheel, assembled	Rueda de horas, ajustada	Ruota delle ore, montata	2000	2000
260	31.041.00	Minute wheel	Rueda de minutería	Ruota della minuteria	2000	2000
303/5	40.302.23	Two-piece regulator, with pointer, for stud support ETACHRON and corrector	Raqueta de 2 piezas, con flecha para porta-pitón ETACHRON y corrector	Racchetta in 2 pezzi, con freccia, per portapitone ETACHRON e correttore	2000	2000
358	40.380.00	Regulator corrector	Corrector de raqueta	Correttore della racchetta	2000	2000
375	40.200.00	Stud support, ETACHRON	Porta-pitón, ETACHRON	Portapitone, ETACHRON	2000	2000
401	51.010.21	Winding stem, thread diameter 0.90 mm	Tija de remontuar, diámetro de fileteado 0,90 mm	Albero di carica, diametro di filettatura 0,90 mm	2000	2000
407	31.121.00	Sliding pinion	Piñón corredizo	Pignone scorrevole	2000	2000
410	31.120.00	Winding pinion	Piñón de remontuar	Pignone di carica	2000	2000
415	31.020.00	Ratchet wheel	Rochete	Rocchetto	2000	2000
435/1	51.050.00	Spring-yoke, assembled	Báscula de piñón corredizo, ajustada	Bascula del pignone scorrevole, montata	2000	2000
443/1	51.080.06	Setting lever, assembled	Tirete, ajustado	Tiretto, montato	2000	2000
445	51.091.00	Setting lever jumper	Muelle flexible de tirete	Scatto del tiretto	2000	2000
450	31.100.00	Setting wheel	Rueda de transmisión	Rinvio	2000	2000
453	31.101.00	Intermediate setting wheel	Rueda de transmisión intermedia	Rinvio intermedio	2000	2000
462	10.062.00	Minute train bridge	Puente del rodaje de minutería	Ponte del ruotismo di minuteria	2000	2000
705	30.040.00	Escape wheel	Rueda de escape	Ruota di scappamento	2000	2000
710	40.010.00	Pallet fork	Áncora	Ancora	2000	2000
714	40.020.00	Pallet staff	Tija de áncora	Albero dell'ancora	2000	2000
721	40.050.21	Timed annular balance, for shock-absorber and stud support ETACHRON	Volante anular, regulado, para amortiguador y porta-pitón ETACHRON	Bilanciere regolato, per ammortizzatore e portapitone ETACHRON	2000	2000-1
771	20.102.00	Mainspring with sliding attachment	Muelle motor con muelle de frenar	Molla-motrice con molla di freno	2000	2000
1134/1	12.030.07	Automatic device framework, jewelled	Marco del dispositivo automático, empedrado	Gabbia del dispositivo automatico, con pietre	2000	2000
1141	12.051.07	Automatic device lower bridge, jewelled	Puente inferior del dispositivo automático, empedrado	Ponte inferiore del dispositivo automatico, con pietre	2000	2000
1143/1	22.010.06	Oscillating weight, assembled	Masa oscilante, ajustada	Massa oscillante, montata	2000	2000
1467	12.123.00	Reversing wheel maintaining plate	Placa de sujeción de rueda de inversión	Placca di guardia della ruota d'inversione	2000	2000
1471	32.105.00	Stop pinion	Piñón de parada	Pignone d'arresto	2000	2000
1481	32.081.00	Reduction wheel	Rueda de reducción	Ruota di riduzione	2000	2000
1488	32.037.00	Reversing wheel	Rueda de arrastre de rochete	Ruota conduttrice del rocchetto	2000	2000

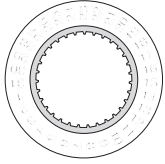
Interchangeability - Intercambiabilidad - Intercambiabilità

No No No	No No CS No	LIST OF MATERIALS	LISTA DE FORNITURAS	ELENCO DELLE FORNITURE	Cal. - Cal.- Cal	
					2000	2000-1
1491	52.120.00	Oscillating weight bolt	Cerrojito de rueda de reducción	Paletto della massa oscillante	2000	2000
1497	22.010.00	Ball bearing	Rodamiento de bolillas	Cuscinetto a sfere	2000	2000
1514	52.041.00	Auxiliary reverser	Inverso auxiliar	Invertitore ausiliario	2000	2000
2539	53.022.00	Date corrector operating lever	Mando del corrector de fecha	Commando del correttore della data	2000	2000
2543	33.011.00	Intermediate date wheel	Rueda auxiliar de inversión	Ruota ausiliaria d'inversione	2000	2000
2556	33.020.00	Date indicator driving wheel	Rueda de arrastre del indicador de fecha	Ruota conduttrice dell'indicatore della data	2000	2000
2557/1	91.440.00	Date indicator, for window opening at 3 o'clock	Indicador de fecha, para abertura de ventanilla en 3 h	Indicatore della data, per apertura a sportellino alle 3 ore	2000	2000
2566	53.200.00	Date corrector	Corrector de fecha	Correttore della data	2000	2000
2576	53.080.00	Date jumper	Muelle flexible de fecha	Scatta-data	2000	2000
2595	13.111.00	Date jumper maintaining plate	Placa de sujeción del muelle flexible de fecha	Placca di guardia dello scatto-data	2000	2000
3024	70.530.00	Jewelled shock-absorber for balance, top, to press in, cylindrical	Amortiguador, empedrado, de volante, de embutir, de asiento, encima	Ammortizzatore, con pietre, del bilanciere, a pressione, con piano d'appoggio, sopra	2000	2000
3025	70.531.00	Jewelled shock-absorber for balance, bottom, to press in, cylindrical	Amortiguador, empedrado, de volante, de embutir, cilíndrico, debajo	Ammortizzatore, con pietre, del bilanciere, a pressione, cilíndrico, sotto	2000	2000
9433	56.070.00	Stop lever	Palanquita-stop	Leva stop	2000	2000
5102	10.020.02	2x Case screw, special	Tornillo de fijación, especial	Vite di fissaggio, speciale	2000	2000
1) 5105	10.041.01	2x Screw for barrel bridge	Tornillo del puente de cubo	Vite del ponte del bariletto	2000	2000
1) 5110	10.048.01	2x Screw for train wheel bridge	Tornillo del puente de rodaje	Vite del ponte del ruotismo	2000	2000
1) 5121	10.058.01	1x Screw for balance bridge	Tornillo del puente de volante	Vite del ponte del bilanciere	2000	2000
1) 5125	10.057.01	1x Screw for pallet bridge	Tornillo del puente de áncora	Vite del ponte d'ancora	2000	2000
2) 5445	51.091.01	2x Screw for combined setting lever jumper	Tornillo del muelle flexible de tirete combinado	Vite dello scatto del tiretto multiplo	2000	2000
2) 5462	10.062.01	1x Screw for minute train bridge	Tornillo del puente de rodaje de minutería	Vite del ponte del ruotismo di minutería	2000	2000
1) 51134	12.030.01	3x Screw for automatic device framework	Tornillo del marco del dispositivo automático	Vite della gabbia del dispositivo automatico	2000	2000
2) 51141	12.051.01	2x Screw for automatic device lower bridge	Tornillo del puente inferior del dispositivo automático	Vite del ponte inferiore del dispositivo automatico	2000	2000
2) 51467	12.123.01	1x Screw for reversing wheel maintaining plate	Tornillo de placa de sujeción de rueda de inversión	Vite della placca di guardia della ruota d'inversione	2000	2000
51143	22.010.01	3x Screw for oscillating weight	Tornillo de masa oscilante	Vite della massa oscillante	2000	2000
2) 52595	13.111.01	1x Screw for maintaining plate date jumper	Tornillo de la placa de sujeción del muelle flexible de fecha	Vite della placca di guardia dello scatto-data	2000	2000
		Identical screws	1) 5105			
		Tornillos idénticos	5110			
		Vite identiche	5121			
			5125			
			51134			
			2) 5445			
			5462			
			51141			
			51467			
			52595			

Materials - Fornituras - Forniture

										T 5102		
100	105/1	110	121/4	125	144	161	180/1	185	190			
												T 5105 5110 5121 5125 51134
195	203	210	227	242	255/1	260	303/5	358	375	401	407	
											T 5445 5462 51141 51467 52595	
410	415	435/1	443/1	445	450	453	462	705	710	721		
									T 51143			
771	1134/1	1141	1143/1	1467	1471	1481	1488	2539				
												
2543	2556	2557/1	2566	2576	2595	3024	3025	9433				

Assembling of the basic movement

(Parts listed in order of assembly)

Montaje de la máquina de base





(Lista de fornituras por orden de ensamblado)

Montaggio del movimento di base

(Elenco delle forniture per ordine di montaggio)

100	227
161	110
3025	5110 (2x)
407	710
410	125
401	5125 (2x)
9433	358
203	375
180/1	303/5
415	3025
105/1	3024
5105 (2x)	721
705	121/4
210	5121

Lubrication – Lubricación – Lubrificazione

	Fine oil	
	Aceito fino	Moebius 9010
	Olio fluido	
	Thick oil or grease	
	Aceite espeso o grasa	Moebius D5
	Olio denso o grasso	
	Special oil for pallet stones	
	Aceite especial para escape	Moebius 941
	Olio speciale per scappamento	or / ó / o
		Moebius 9415
	Very small quantity	
	Cantidad muy pequeña	Moebius 9010
	Piccolissima quantità	

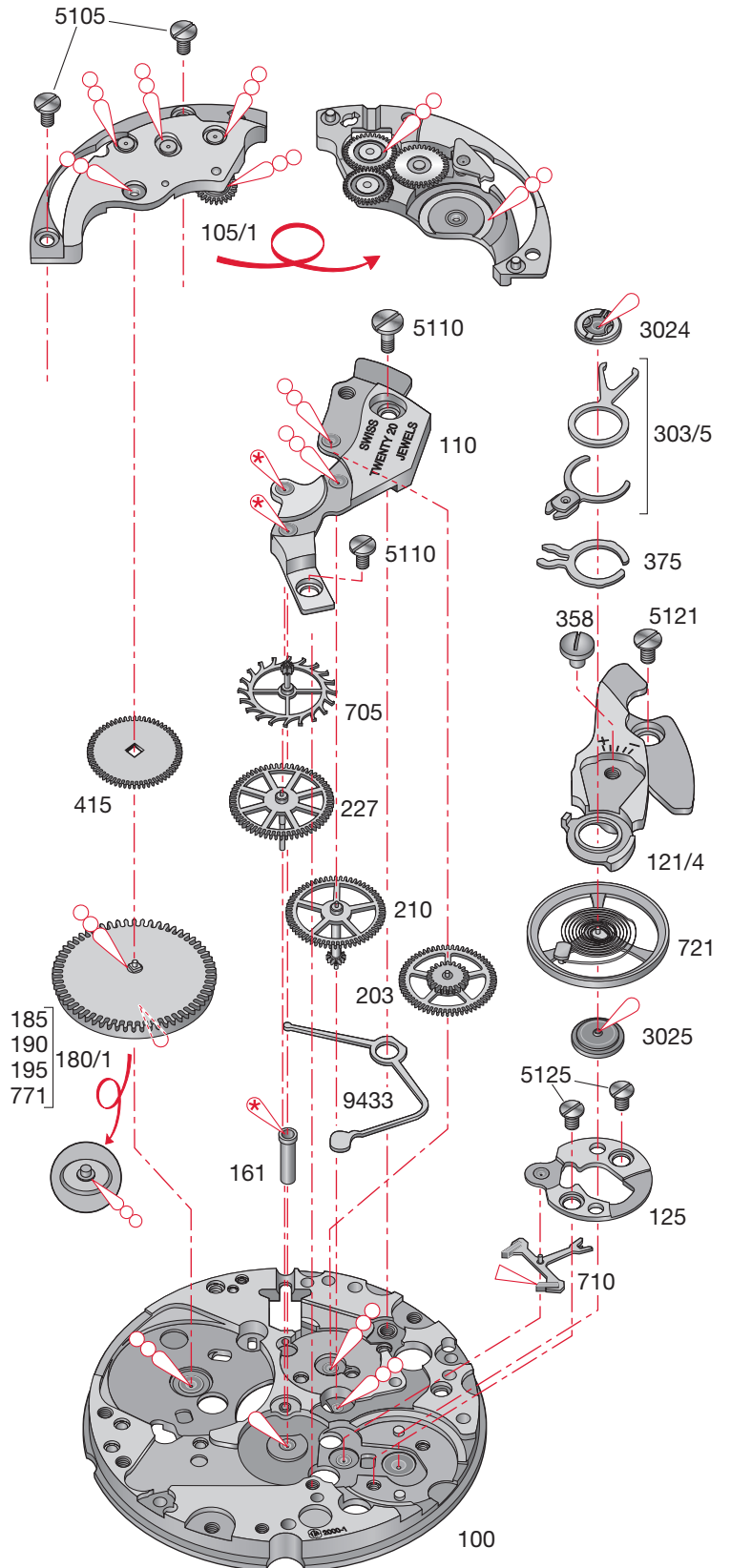

No 1497 : only after washing, use very little oil
Moebius 9010.

No 1497 : sólo después de la limpieza
por lavado, muy pequeña
lubricación con Moebis 9010.

No 1497 : soltanto dopo politura col lavaggio,
molto debole lubrificazione con
Moebius 9010.

Assembling of the self-winding mechanism
(Parts listed in order of assembly)

Montaje del mecanismo automático
(Lista de forniture por orden de ensablado)

Montaggio del meccanismo automatico
(Elenco delle forniture per ordine di montaggio)

1134/1	1467
1481	51467
1141	1143/1
51141 (2x)	51143 (3x)
1471	51134 (3x)
1488	

Lubrication – Lubricación – Lubrificazione

	Fine oil	
	Aceite fino	Moebius 9010
	Olio fluido	
	Very small quantity	
	Cantidad muy pequeña	Moebius 9010
	Piccolissima quantità	
	Thick oil or grease	
	Aceite espeso o grasa	Moebius D5
	Olio denso o grasso	

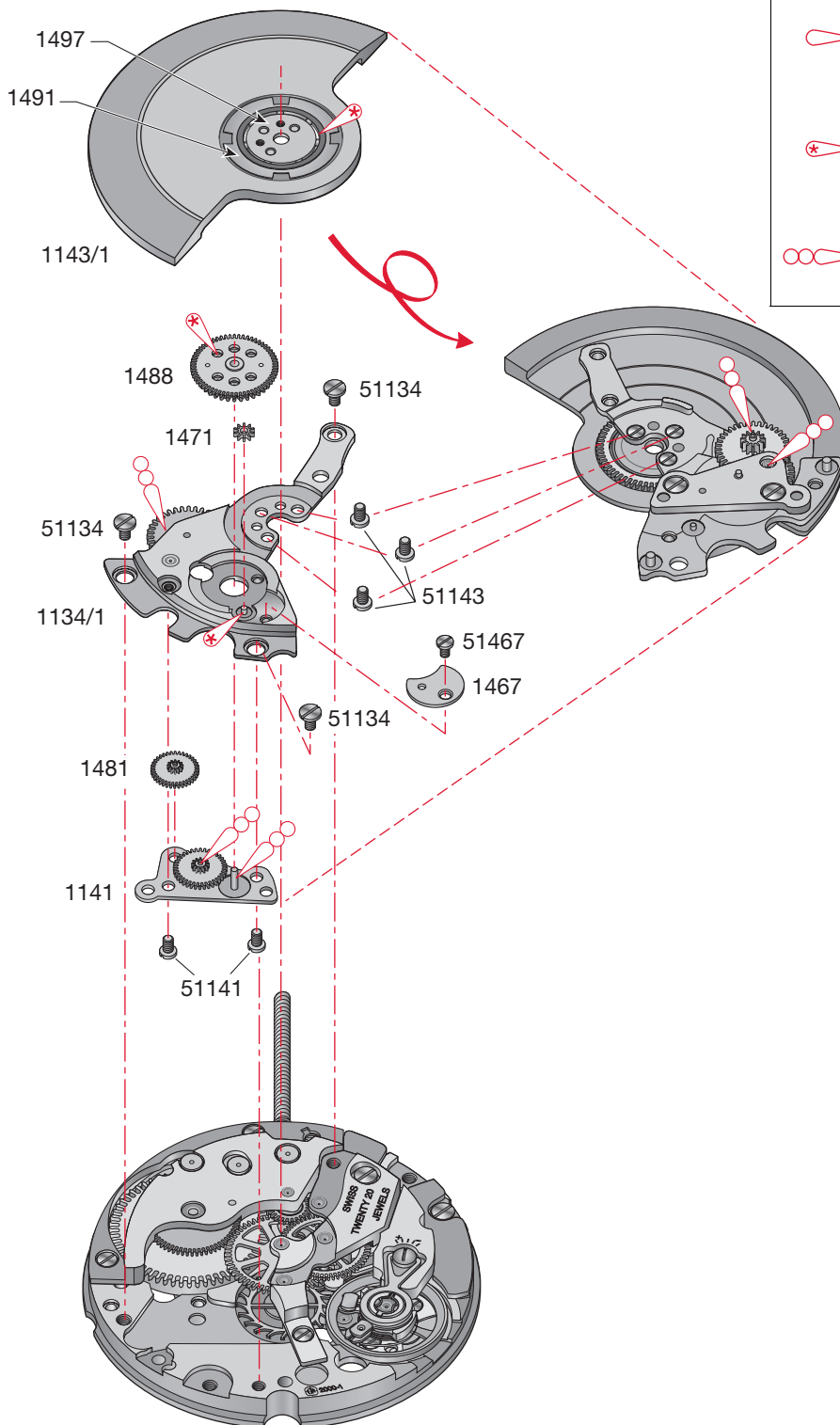

Assembling of the hand-winding, hand-setting, date and corrector mechanisms

(Parts listed in order of assembly)

Montaje del mecanismo: de cuerda manual, de puesta en hora, de fecha y de corrector



(Lista de fornitureas por orden de ensamblado)

Montaggio del meccanismo: a carica manuale, della messa all'ora, delle date e del correttore

(Elenco delle forniture per ordine di montaggio)

2539	462
443/1	5462
435/1	2556
445	2557/1
5445 (2x)	2543
242	2576
260	5295
450	52595
453	255/1
2566	

Lubrication – Lubricación – Lubrificazione

	Thick oil or grease	
	Aceite espeso o grasa	Moebius D5
	Olio denso o grasso	
	Grease	
	Grasa	Jismaa 124
	Grasso	

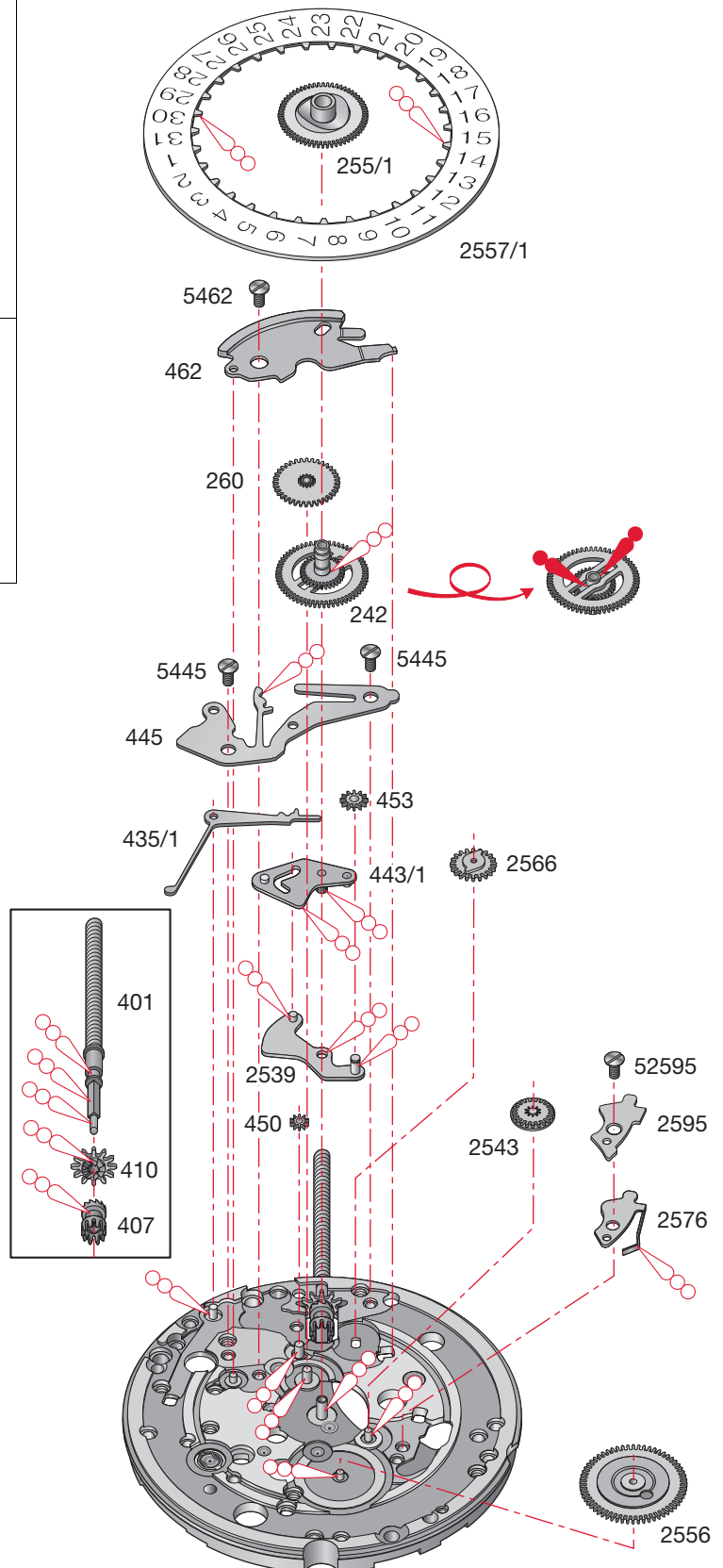

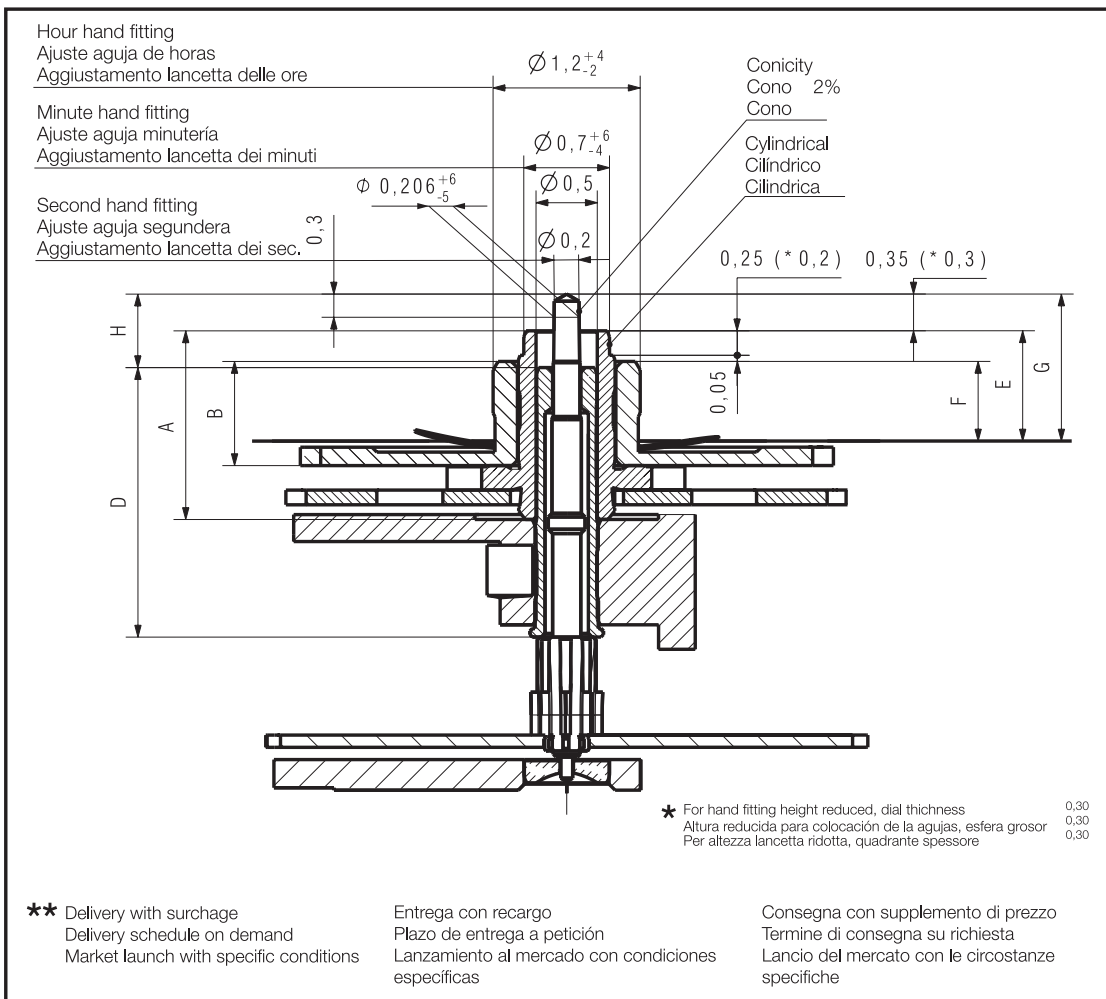

Hand fitting heights Ajuste de la agujas Aggiustamento lancette	Length / Longitudes / Lunghezze				Height over dial seat Exceso en mm en relación con la platina Sorpassi in mm rispetto alla piastra			H
	A	B	C	D	E	F	G	
	Cannon-pinion Cañón de minutos Pignone calzante	Hour wheel Rueda de horas Ruota delle ore	Sec. wheel pin. Piñón de seg. Pignone dei sec.	Centre tube Tubito de centro Tubo di centro	Cannon-pinion Cañón de minutos Pignone calzante	Hour wheel Rueda de horas Ruota delle ore	Sec. wheel pin. Piñón de seg. Pignone dei sec.	
Reduced * Reducido Ridotto	1,54	0,85	3,98	2,20	0,90	0,65	1,20	0,60
1 normal	1,74	1,00	4,23	2,20	1,10	0,80	1,45	0,85
2 **	1,99	1,25	4,48	2,20	1,35	1,05	1,70	1,10
3 **	2,24	1,50	4,73	2,20	1,60	1,30	1,95	1,35

Kaliber / Calibre / Caliber 2000-1 2004-1		Masstab Echelle Scale		CATIA V5
		Masse in mm Dimensions en mm Dimensions in mm		
Hand fitting height Ajuste de la agujas Aggiustamento lancette		Z0091638	Version 01	Revision 00
		Blatt Feuille Sheet 01		
Ersatz für En remplacement de Remplacement for		Klass. ZVACC KUN		
Aenderung Modification	Geprüft Contrôlé Controlled	Freigegeben Libéré Released	Erstellt Etabli Created	Geprüft Contrôlé Controlled
19444 BER	30.09.2004	HID	01.10.2004	FEU



Ogni diritto su questo documento è riservato. Il documento è indirizzato esclusivamente al destinatario e non può essere copiato, stampato o ceduto a terzi senza un'autorizzazione scritta.

Quedan reservados todos los derechos relacionados con este documento, que está dirigido únicamente al destinatario. Queda por lo tanto prohibida su copia, impresión o cesión a terceros sin nuestra autorización por escrito.

We reserve all rights for this document. It is meant for the recipient only and it may not be copied, printed or given to a third person without our written permission.

Ogni diritto su questo documento è riservato. Il documento è indirizzato esclusivamente al destinatario e non può essere copiato, stampato o ceduto a terzi senza un'autorizzazione scritta.

Quedan reservados todos los derechos relacionados con este documento, que está dirigido únicamente al destinatario. Queda por lo tanto prohibida su copia, impresión o cesión a terceros sin nuestra autorización por escrito.

We reserve all rights for this document. It is meant for the recipient only and it may not be copied, printed or given to a third person without our written permission.

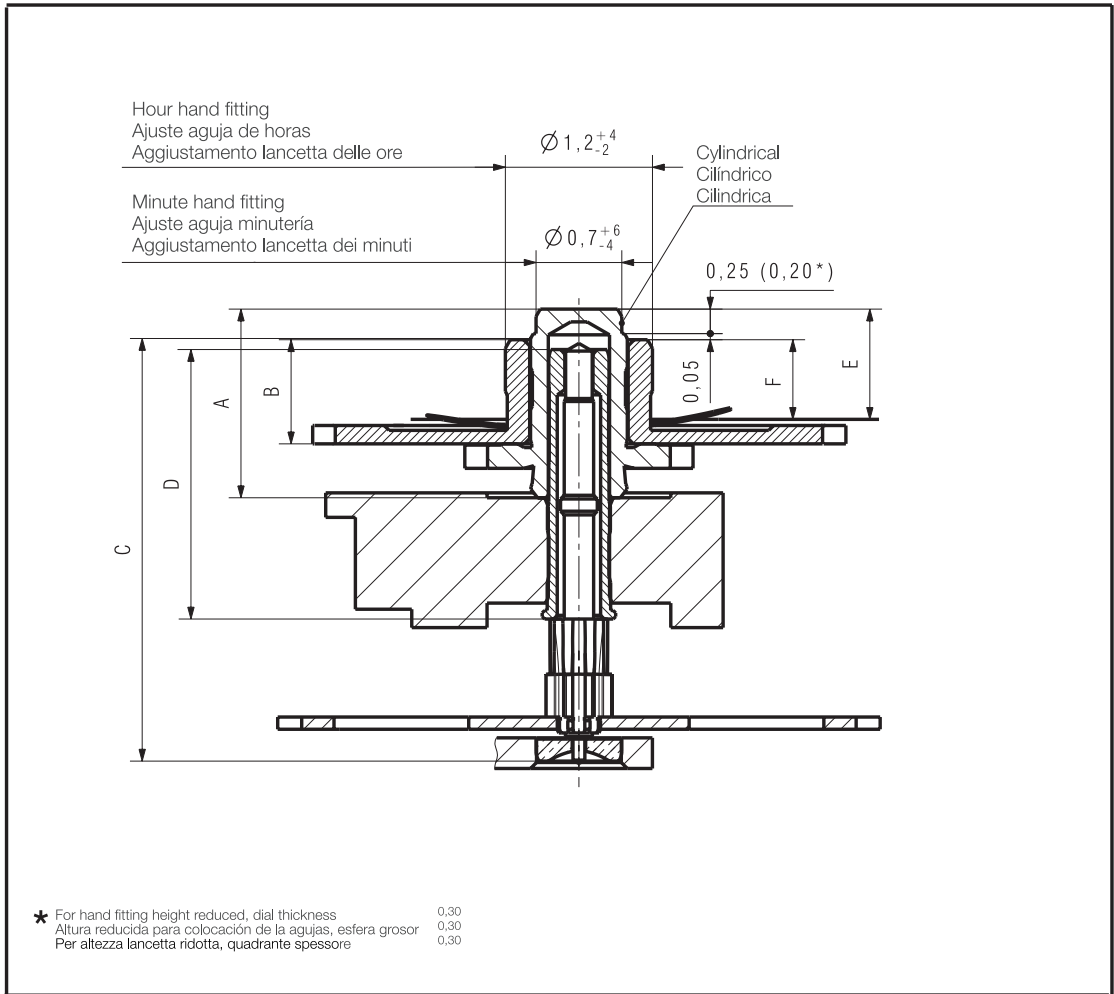

Hand fitting heights Ajuste de la agujas Aggiustamento lancette	Length / Longitudes / Lunghezze				Height over dial seat Exceso en mm en relación con la platina Sorpassi in mm rispetto alla piastra	
	A	B	C	D	E	F
	Cannon-pinion Cañón de minutos Pignone calzante	Hour wheel Rueda de horas Ruota delle ore	Sec. wheel pin. Piñón de seg. Pignone dei sec.	Centre tube Tubito de centro Tubo di centro	Cannon-pinion Cañón de minutos Pignone calzante	Hour wheel Rueda de horas Ruota delle ore
Reduced * Reducido Ridotto	1,54	0,85	3,43	2,20	0,90	0,65
1	1,74	1,00	3,43	2,20	1,10	0,80
2	1,99	1,25	3,43	2,20	1,35	1,05
3	2,24	1,50	3,43	2,20	1,60	1,30

Kaliber / Calibre / Caliber 2000-1 2004-1		Massestab Echelle Scale		CATIA V5	
				Masse in mm Dimensions en mm Dimensioni in mm Tol. 1/1000 mm	
Hand fitting height Ajuste de la agujas Aggiustamento lancette		Without second Sin segundero Senza secondi		Z0091699	Version 01
Ersatz für En remplacement de Remplacemnt for		Klass. Class. ZVACC		Blatt Feuille Sheet 01	
Aenderung Modification	Geprüft Contrôlé Controlled	Freigegeben Libéré Released	Erstellt Etabli Created	Geprüft Contrôlé Controlled	Freigegeben Libéré Released
19444 BER	30.09.2004	HID 01.10.2004	FEU	15.07.2004	BER 17.08.2004 MAL 01.10.2004 FEU



This page was left blank intentionally.

Esta página ha sido dejada en blanco intencionadamente.

Questa pagina è stata lasciata vuota intenzionalmente.

This page was left blank intentionally.

Esta página ha sido dejada en blanco intencionadamente.

Questa pagina è stata lasciata vuota intenzionalmente.



ETA SA Manufacture Horlogère Suisse

Customer Service

Bahnhofstrasse 9

P.O. Box 359

CH - 2540 Grenchen

Phone: +41 (0)32 655 27 77

Fax: +41 (0)32 655 84 30

e-mail: etacs@eta.ch

www.eta.ch